

Agilent 1260 Infinity Multiple Wavelength Detector

Features, Technical Details, Specifications and Ordering Details



Real multiple wavelength detection for ultrafast LC

The Agilent 1260 Infinity Multiple Wavelength detector (MWD) provides simultaneous detection of up to 8 compound specific wavelengths for optimum selectivity over a wavelength range from 190 nm to 950 nm. The improved diode array design offers very low detector noise ($< \pm 7 \mu\text{AU}$) for precise quantification of trace levels, regardless of how many signals are recorded. High-speed UV detection with up to 80 Hz data rates keeping pace with the analysis speed of fast LC.

Features

- Simultaneous acquisition of up to 8 compound-specific wavelengths for increased sensitivity and selectivity.
- Low noise front-end electronics and the patented flow cell design delivers very low detection limits resulting from minimized short-term noise ($< \pm 7 \mu\text{AU}$).
- Up to 100% resolution gain in fast LC by 80 Hz data acquisition rate.
- Electronic temperature control (ETC) - maximum baseline stability and practical sensitivity under fluctuating ambient temperature and humidity conditions.
- Wide linear range – for reliable, simultaneous quantification of primary compounds, by-products and impurities.
- Programmable slit (1 to 16 nm) for rapid optimization of sensitivity and linearity.
- New data recovery card (DRC) and radio frequency identification (RFID) technology provide new levels of data security and traceability.
- Automatic wavelength verification by built-in holmium oxide filter.
- Range of 9 analytical and preparative flow cells provide maximum application flexibility.
- Extensive diagnostics, error detection and display with Agilent 1200 Series Instant Pilot controller and Agilent Lab Advisor software.



Agilent Technologies

Technical Details – Agilent 1260 Infinity Multiple Wavelength Detector

Diode-array design for uncompromised sensitivity

With conventional scanning UV-detectors the sensitivity is decreasing with the numbers of acquired signals. The 1260 Infinity multiple wavelength detector is based on an improved diode array design which offers the same high sensitivity for both single and multiple wavelength detection.

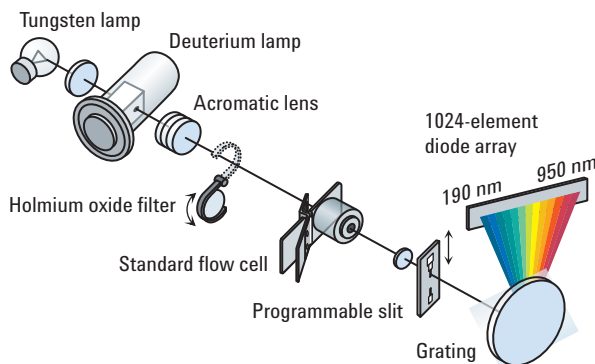

A long-life (> 2000 hours) deuterium lamp reduces operating costs.

Multiple wavelength detection for increased sensitivity and selectivity

The 1260 Infinity multiple wavelength detector allows the simultaneous acquisition of up to 8 compound-specific wavelengths. This ensures optimum detection conditions in terms of selectivity and sensitivity especially for closely eluting compounds.

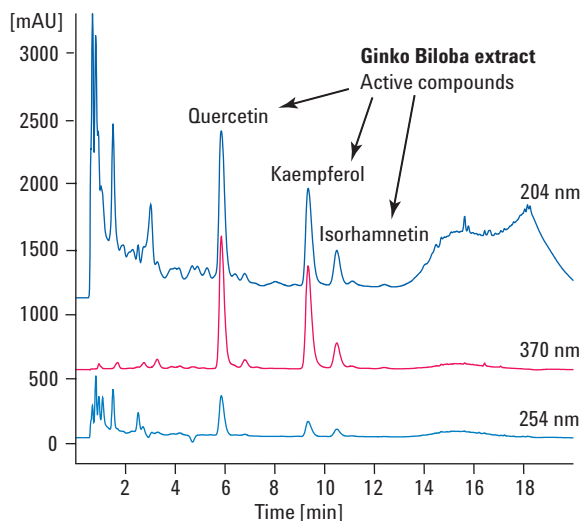

Sensitive quantitation of active compounds and impurities in a single run without wavelength switching.

Maximum baseline stability

The electronic temperature control reduces baseline wander by more than a factor of 20. Even under the harshest ambient conditions, the baseline of the Agilent 1260 Infinity MWD remains constant within 30 μ AU/ $^{\circ}$ C.

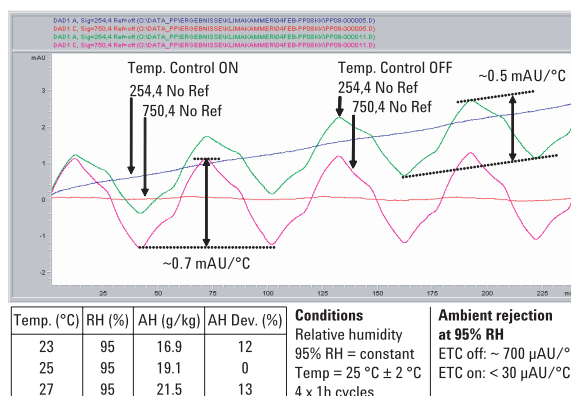

Note: By keeping RH=const. the absolute humidity is strongly modulated due to temperature variations (worst case conditions).

Baseline wander with electronic temperature control turned on and off.

80 Hz data rates for fast LC

Fast LC analyses can generate sharp and narrow peaks with peak widths smaller than 1 second. The 1260 Infinity multiple wavelength detectors offer multiple wavelength detection of 8 signals at 80 Hz data rate, keeping pace with the analysis speed of fast LC.

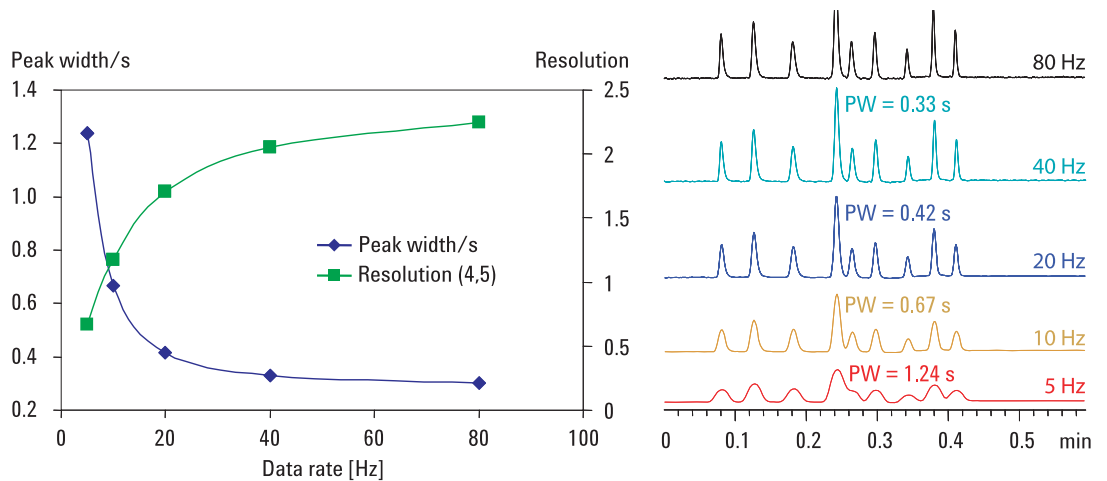

80 Hz full spectral sampling rate provides resolution and peak capacity gains of 90% (30%) relative to 10 Hz (20 Hz) sampling rates.

New level of data security and traceability

“Data-never-lost-insurance” with built-in data recovery card (DRC) prevents data losses in the event of communication breakdowns between instrument and PC by automatically buffering raw and meta-data on an embedded memory card. Radio frequency identification (RFID) tags for all flow cells and UV lamp provide highest levels of data traceability by recording parameters, such as product and serial number, production date, cell dimensions, lamp usage, and the date of the last successful cell or lamp test.



Data recovery card offers “data never lost” insurance and prevents data losses by buffering raw and metadata

Specifications – Agilent 1260 Infinity Multiple Wavelength Detectors

Specifications: 1260 Infinity Multiple Wavelength Detector (G1365C)	
Detector type	1024-element diode array
Light source	Deuterium and tungsten
Number of signals	8
Maximum sampling rate	80 Hz
Short-term noise	$< \pm 0.7 \times 10^{-5}$ AU at 254/4 nm and at 750 nm, TC 2 sec. cell
Drift	$< 0.9 \times 10^{-3}$ AU/hr at 254 nm
Linearity	> 2.0 AU (5 %) at 265 nm
Wavelength range	190-950 nm
Wavelength accuracy	± 1 nm, self-calibration with deuterium lines. Verification with holmium oxide filter,
Slit width	Programmable: 1, 2, 4, 8, 16 nm
Diode width	< 1 nm
Wavelength bunching	Programmable, 1 - 400 nm, in steps of 1 nm
Flow cells	<p>Standard 13-μL volume, 10 mm-cell path length, 120 bar (1740 psi) pressure maximum</p> <p>Semi-micro 5-μL volume, 6-mm cell path length, 120 bar (1740 psi) pressure maximum</p> <p>Micro 2-μL, volume, 3-mm cell path length, 120 bar (1740 psi) pressure maximum</p> <p>Semi-nano 500-nanoliter volume, 10-mm cell path length, 50 bar (725 psi) pressure maximum</p> <p>Nano 80-nanoliter volume, 6-mm cell path length, 50 bar (725 psi) pressure maximum</p> <p>High Pressure (for SFC) 1.7-μL volume, 6-mm cell path length, 400 bar (5802 psi) pressure maximum</p> <p>Preparative 3 mm 3-mm cell path length, 120 bar (1740 psi) pressure maximum</p> <p>Preparative 3 mm 0.3-mm cell path length, 20 bar (291 psi) pressure maximum, quartz</p> <p>Preparative 0.06 mm 0.06-mm cell path length, 20 bar (291 psi) pressure maximum, quartz</p>
Time programmable	Wavelength, polarity, peak width, lamp bandwidth, autobalance, wavelength range, threshold, spectra storage mode.
Analog output	Recorder/integrator: 100 mV or 1 V, 2 outputs.
Communications	LAN, Controller-area network (CAN), RS-232C, APG Remote: ready, Start, stop and shut-down signals.
GLP features	<p>Data recovery card to prevent data losses. RFID for electronics records of flow cell and UV lamp conditions (path length, volume, product number, serial number, test passed, usage)</p> <p>Early maintenance feedback (EMF) for continuous tracking of instrument usage in terms of lamp burn time with user settable limits and feedback messages. Electronic records of maintenance and errors. Verification of wavelength accuracy with built-in holmium oxide filter.</p>
Safety and maintenance	Extensive diagnostics, error detection and display through Agilent Instant Pilot and Agilent Lab Advisor software. Leak detection, safe leak handling, and leak output signal for shutdown of pumping system. Low voltages in major maintenance areas.
Others	Electronic temperature control (ETC) for the complete optical unit.

Specifications: 1260 Infinity Multiple Wavelength Detector VL (G1365D)	
Detector type	1024-element diode array
Light source	Deuterium and tungsten
Number of signals	8
Maximum sampling rate	20 Hz
Short-term noise	$< \pm 0.7 \times 10^{-5}$ AU at 254/4 nm and at 750 nm, TC 2 sec.
Drift	$< 0.9 \times 10^{-3}$ AU/hr at 254 nm
Linearity	> 2.0 AU (5 %) at 265 nm
Wavelength range	190-950 nm
Wavelength accuracy	± 1 nm, self-calibration with deuterium lines verification with holmium oxide filter.
Slit width	Programmable: 1, 2, 4, 8, 16 nm
Diode width	< 1 nm
Wavelength bunching	Programmable, a - 400 nm, in steps of 1 nm
Flow cells	<p>Standard 13-μL volume, 10 mm-cell path length, 120 bar (1740 psi) pressure maximum</p> <p>Semi-micro 5-μL volume, 6-mm cell path length, 120 bar (1740 psi) pressure maximum</p> <p>Micro 2-μL, volume, 3-mm cell path length, 120 bar (1740 psi) pressure maximum</p> <p>Semi-nano 500-nanoliter volume, 10-mm cell path length, 50 bar (725 psi) pressure maximum</p> <p>Nano 80-nanoliter volume, 6-mm cell path length, 50 bar (725 psi) pressure maximum</p> <p>High Pressure (for SFC) 1.7-μL volume, 6-mm cell path length, 400 bar (5802 psi) pressure maximum</p> <p>Preparative 3 mm 3-mm cell path length, 120 bar (1740 psi) pressure maximum</p> <p>Preparative 3 mm 0.3-mm cell path length, 20 bar (291 psi) pressure maximum, quartz</p> <p>Preparative 0.06 mm 0.06-mm cell path length, 20 bar (291 psi) pressure maximum, quartz</p>
Time programmable	Wavelength, polarity, peak width, lamp bandwidth, autobalance, wavelength range, threshold, spectra storage mode.
Analog output	Recorder/integrator: 100 mV or 1 V, 2 outputs
Communications	LAN, Controller-area network (CAN), RS-232C, APG Remote: ready start, stop and shut-down signals,
GLP features	<p>RFID for electronics records of flow cell and UV lamp conditions (path length, volume, product number, serial number, test passed, usage)</p> <p>Early maintenance feedback (EMF) for continuous tracking of instrument usage in terms of lamp burn time with user settable limits and feedback messages. Electronic records of maintenance and errors. Verification of wavelength accuracy with built-in holmium oxide filter.</p>
Safety and maintenance	Extensive diagnostics, error detection and display through Agilent Instant Pilot and Agilent Lab Advisor software. Leak detection, safe leak handling, leak output signal for shutdown of pumping system. Low voltages in major maintenance areas.
Others	Electronic temperature control (ETC) for the complete optical unit.

Ordering Details – Agilent 1260 Infinity Multiple Wavelength Detector

Description	Product Number
Agilent 1260 Infinity Multiple Wavelength Detector Includes CAN cable and LAN interface with cable. Must order one flow cell.	G1365C
Micro flow cell 2 µL volume, 3 mm path length, 120 bar pressure limit.	#010
Nano flow cell 80 nL volume, 6 mm path length, 50 bar pressure limit.	#012
Semi-nano flow cell 500 nL volume, 10 mm path length, 50 bar pressure limit.	#014
Semi-micro flow cell 5 µL volume, 6 mm path length, 120 bar pressure limit.	#016
Standard flow cell 13 µL volume, 10 mm path length, 120 bar pressure limit.	#018
Micro, high-pressure flow cell (for SFC) 1.7 µL volume, 6-mm path length, 400 bar pressure limit.	#020
Preparative flow cell 3 mm 4 µL volume, 3 mm path length, 120 bar pressure limit.	#022
Preparative flow cell 0.3 mm 0,3 mm path length, 20 bar, pressure limit.	#024
Preparative flow cell 0.06 mm 0,06 mm path length, 20 bar, pressure limit.	#026

www.agilent.com/chem/1200

© Agilent Technologies, Inc., 2010
Published in USA, July 1, 2010
Publication Number 5990-6109EN



Agilent Technologies